



JOHNSON GAS APPLIANCE COMPANY
Cedar Rapids, Iowa

FURNACE # 120
INSTRUCTION MANUAL

#120 FURNACE - U.V. SAFETY & AUTO TEMP CONTROL.

FORMS: 1085, 709, A-1983, 320, 318, A-2072, A-2086, 85-01-00032, A-1996
AND C-2056

INSTALLATION OF FURNACE WITH CONSOLE

POSITION FURNACE AND CONSOLE IN DESIRED LOCATION. THEY SHOULD BE SPACED FAR ENOUGH FROM WALLS TO ALLOW EASY ACCESS FOR MAINTENANCE AND OPERATION.

ANY WALLS, CEILINGS OR FLOORS MADE FROM COMBUSTIBLE MATERIALS THAT ARE SUBJECTED TO THE RADIANT HEAT SHOULD BE PROTECTED WITH INSULATION BOARD OF SIMILAR MATERIAL. ON THE INITIAL HEATUP, CHECK TO SEE IF PROTECTION IS REQUIRED.

FOR EXHAUSTING FUMES AND EXHAUST GASES, A METAL HOOD WITH AN EXHAUST FAN CAN BE USED. THE HOOD SHOULD BE HIGH ENOUGH SO THAT IT DOES NOT INTERFERE WITH THE OPERATOR. A STACK SHOULD NOT BE CONNECTED DIRECTLY TO THE EXHAUST OPENING ON THE FURNACE.

CONNECT THE FLEXIBLE METAL HOSE BETWEEN THE FURNACE AND THE CONSOLE. DO NOT ADD PIPING BETWEEN THE FURNACE AND THE CONSOLE AS THIS WILL ADD RESTRICTION AND THE FURNACE WILL NOT OPERATE PROPERLY.

MAKE SURE THE SPARK IGNITER IS POSITIONED PROPERLY: CONNECT THE IGNITION CABLE FROM THE CONSOLE TO THE SPARK IGNITER.

IF ULTRA-VIOLET SAFETY SYSTEM WAS ORDERED WITH THE FURNACE, MAKE SURE THE SCANNER IS POSITIONED PROPERLY.

CONNECT THE GAS LINE TO THE CONSOLE GAS INLET. WHEN THE FURNACE IS IN OPERATION, THE PRESSURE, BEFORE IT GOES INTO THE CONSOLE, SHOULD BE 4" TO 14" WATER COLUMN ON NATURAL GAS AND 11" ON LP GAS.

IF THE TEMPERATURE CONTROL WAS ORDERED WITH THE FURNACE, MOUNT THE CONTROL IN A CONVENIENT LOCATION, AWAY FROM ANY RADIANT HEAT. CONSULT THE ATTACHED WIRING DIAGRAM FOR WIRING AND CONSULT THE CONTROLS INSTRUCTION MANUAL FOR MOUNTING & OPERATION.

CONNECT 115 VOLT-60 CYCLE POWER SOURCE TO THE BLACK AND WHITE LEADS EXTENDING FROM THE CONSOLE. TURN ON MAIN GAS AND POWER SUPPLY. CONSULT LIGHTING AND OPERATING INSTRUCTIONS FOR STARTING FURNACE.

ON THE FIRST HEATUP, THE FURNACE SHOULD BE RUN AT A LOW RATE FOR ABOUT TWO (2) HOURS TO REMOVE THE MOISTURE FROM THE LINING. IT IS NORMAL TO SEE WATER RUN FROM THE FURNACE ON THE FIRST FEW HEATUPS.

AFTER THE FURNACE HAS BEEN HEATED UP AND COOLED, YOU WILL NOTICE CRACKS APPEAR IN THE FURNACE LINING. THIS IS NORMAL DUE TO THE EXPANSION AND CONTRACTION OF THE REFRACTORY AND WILL NOT AFFECT THE PERFORMANCE OF THE FURNACE.

OVEN FURNACE WITH SPARK IGNITION,
CONSOLE, FIREYE FLAME SAFEGUARD

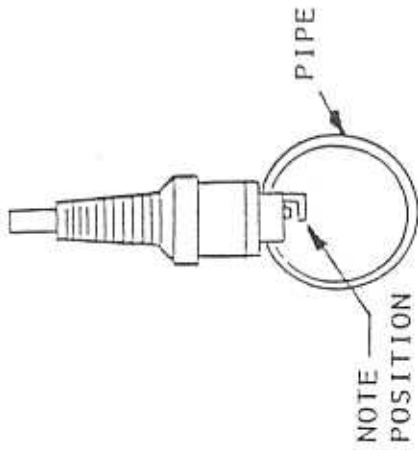

FOR PROPER IGNITION
POSITION SPARK PLUG
AS SHOWN.

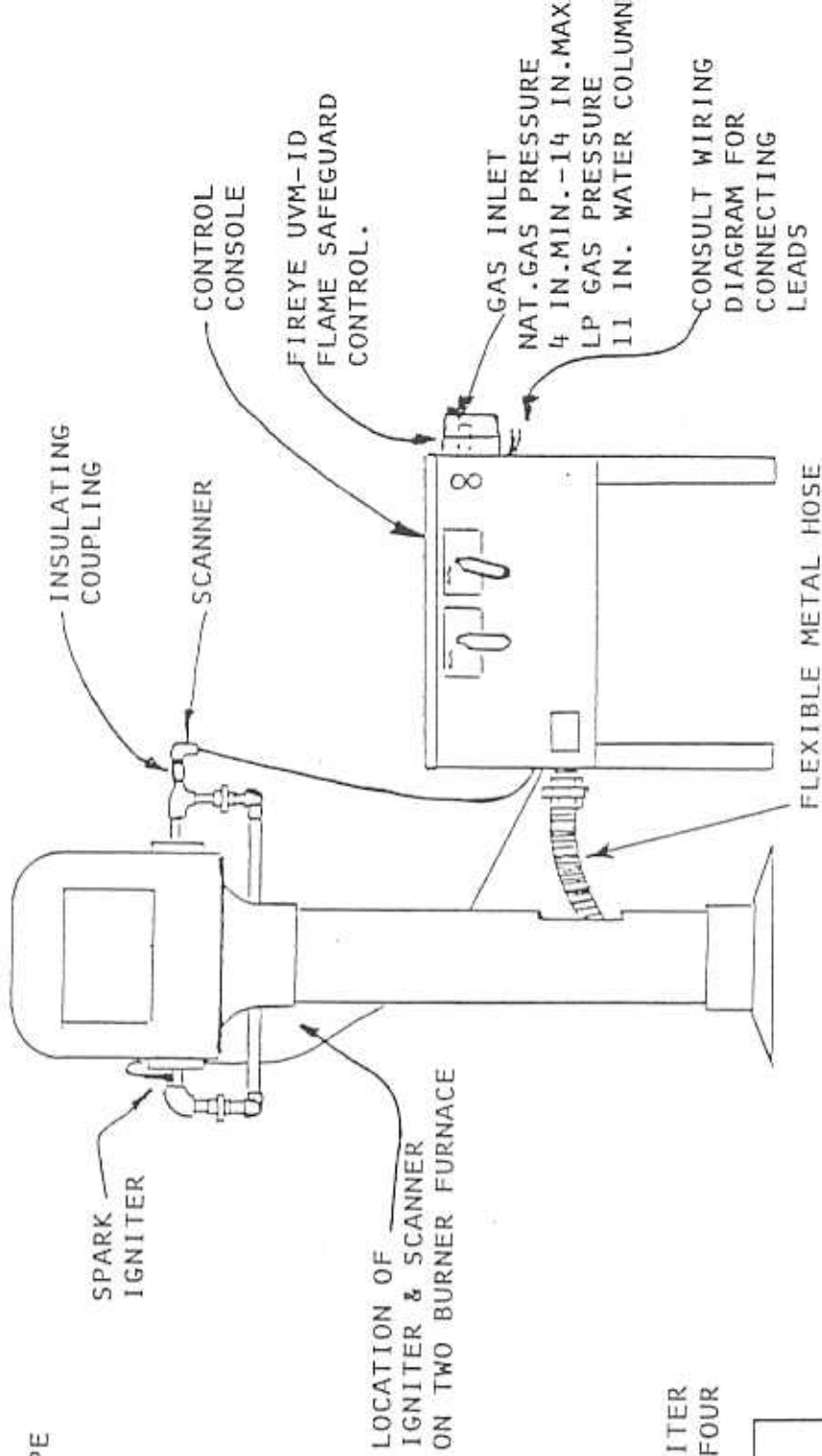

LOCATION OF
IGNITER & SCANNER
ON TWO BURNER FURNACE

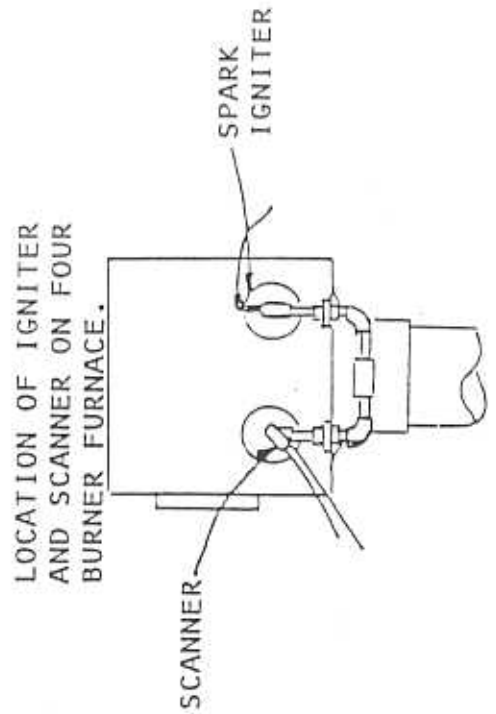

LOCATION OF IGNITER
AND SCANNER ON FOUR
BURNER FURNACE.

CONSULT WIRING
DIAGRAM FOR
CONNECTING
LEADS

IGNITION CONTROLLER AND FLAME SAFEGUARD

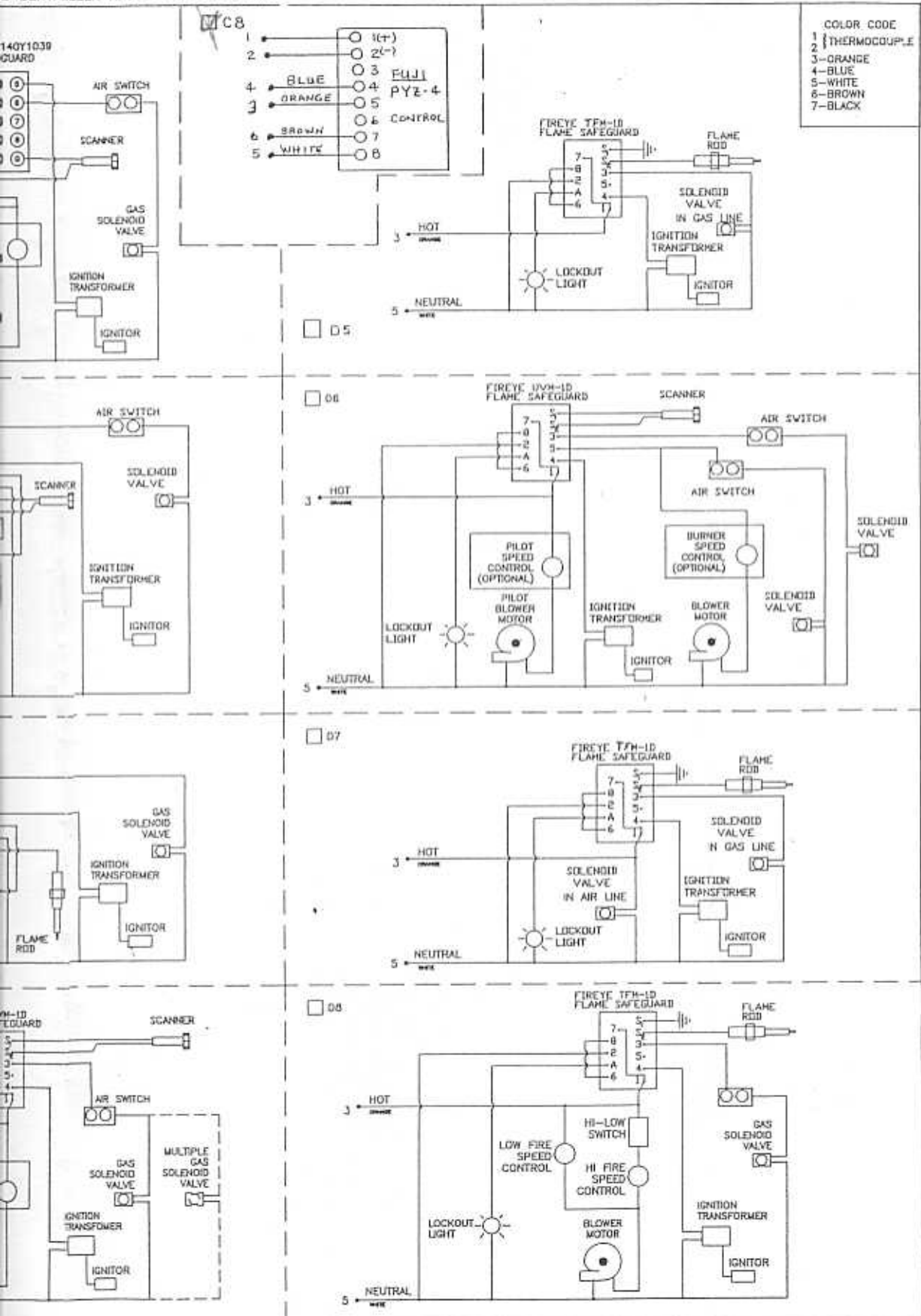

LIGHTING AND OPERATING
INSTRUCTIONS

FORM NO.A-1983

FOR
FURNACE WITH CONSOLE

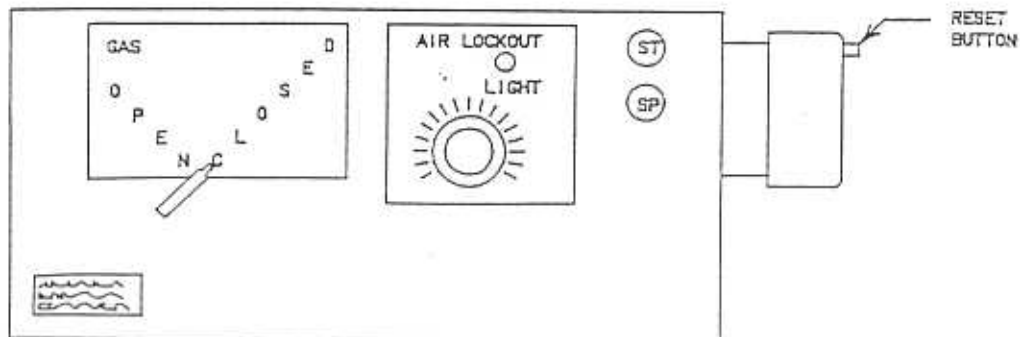

ALL WIRING AND PLUMBING MUST BE COMPLETE BEFORE CONTINUING:

1. Turn the air control knob to number 6. Set the gas control handle to the "CLOSED" position. If you have automatic temperature control, set the control's set point to your desired furnace temperature.

2. Depress and release the start button. The blower motor will start and, after approximately 5 seconds, you will hear the flame safeguard control contacts "click", and the spark igniter will "buzz". Now slowly open the gas control handle just to the position where the burners ignite.

If you depressed the red start button, and the red lockout lamp is "on", you will have to depress the reset button on the flame safeguard control. The red lamp will then go out and the spark igniter will "buzz". Then slowly open the gas control handle until the burners ignite.

If the red flame safeguard did not go out, when you depressed the reset button, wait about 30 seconds and try again.

NOTE: The gas control handle is seldom at the full open position when ignition takes place, but it should be opened slowly until the burners just ignite.

Once ignition takes place, make slight adjustments to the gas control handle to obtain a steady burner "roar".

3. After the furnace has been allowed to warm up for a few minutes, adjust the gas control handle to obtain a sharp tail of flame out the exhaust opening of the furnace. If there is no visible flame, increase the amount of gas slowly. If there is a high, lazy flame, decrease the amount of gas.

4. To reduce the gas input, slightly move the air control knob clockwise. Next adjust the gas control to obtain the desired sharp tail of flame. Repeat this procedure until the desired gas input is reached.

5. To increase the gas input, turn the air control knob counter-clockwise a small amount and re-adjust the gas control to obtain the sharp tail of flame. Repeat this procedure until the desired input is reached.

6. To shut down the furnace, depress and release the "stop" button, and turn the gas control handle to the "closed" position.

FORM#A-1983

JOHNSON GAS APPLIANCE COMPANY

520 E Ave. NW * Cedar Rapids, IA 52405 * Ph: 319-365-5267 or 1-800-553-5422

PXW 4RAY1-4V TEMPERATURE CONTROLLER INSTRUCTIONS

THIS TEMPERATURE CONTROLLER COMES TO YOU WITH ALL OF THE MENU PARAMETERS PRE-PROGRAMMED. THE ONLY PROGRAMMING YOU WILL NEED TO DO IS ENTER YOUR TEMPERATURE SETTING.

TO CHANGE THE SET POINT TEMPERATURE:

- 1) USE THE INCREMENT AND DECREMENT KEYS UNTIL THE DESIRED TEMPERATURE IS DISPLAYED.
- 2) THE NEW SETTING IS SAVED AUTOMATICALLY.

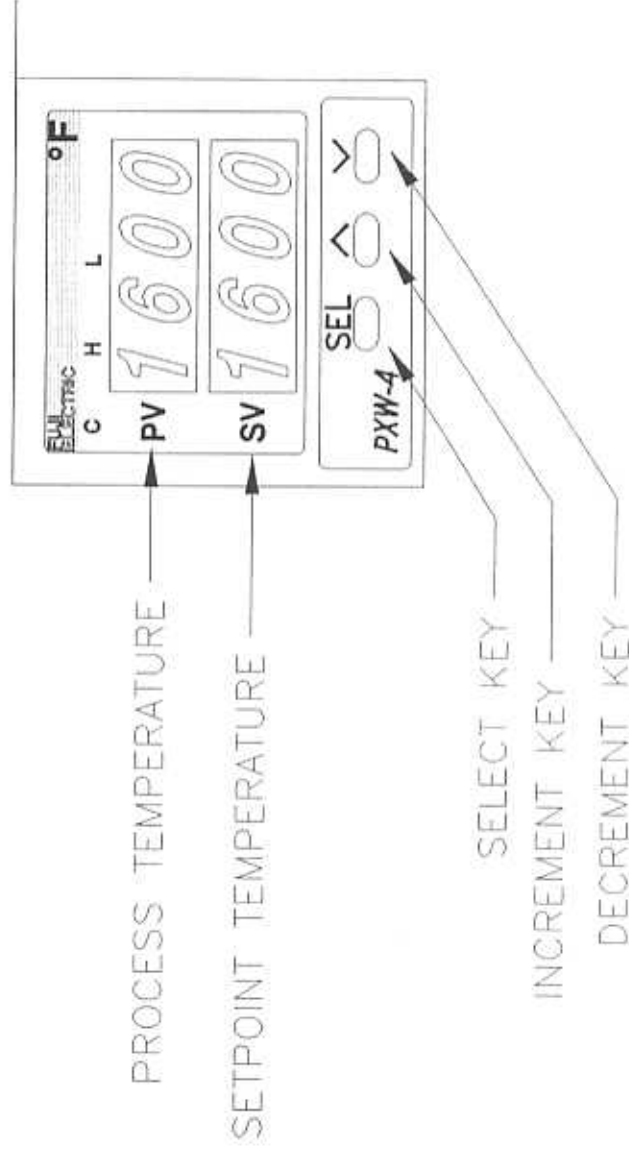

MOUNTING TEMPERATURE CONTROL ON WALL

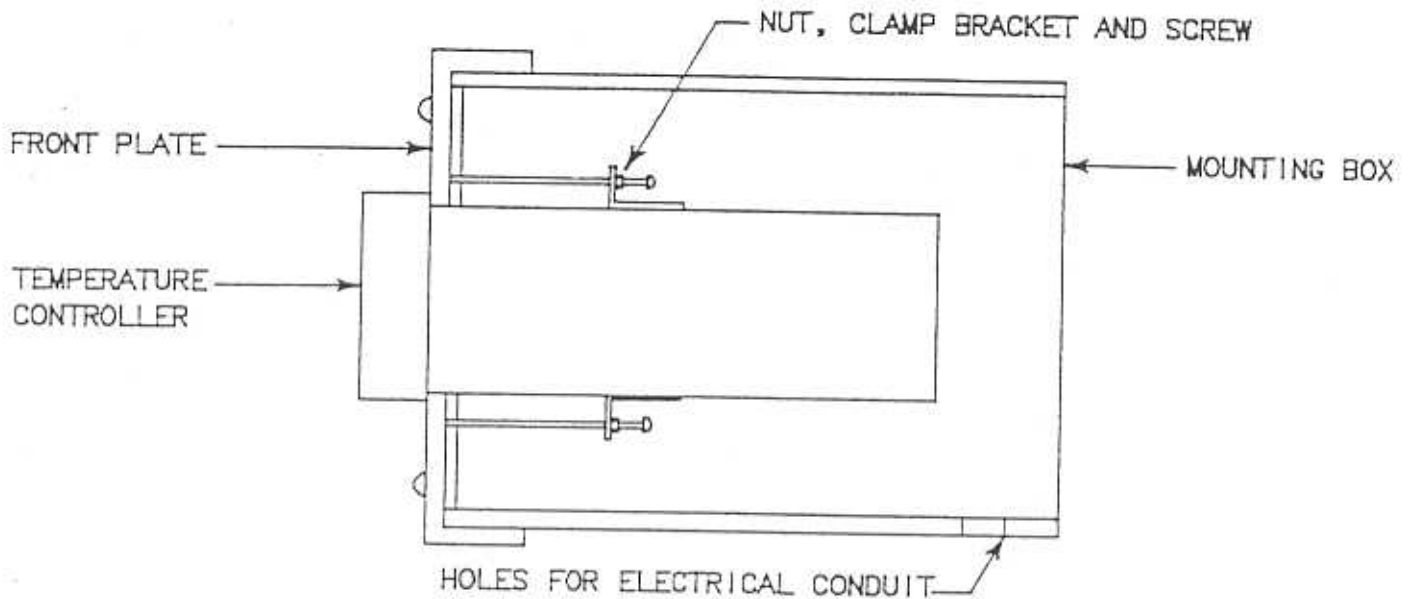

REMOVE THE FRONT PLATE FROM THE MOUNTING BOX, INSERT THE TEMPERATURE CONTROLLER THROUGH THE OPENING AND AGAINST THE FRONT PLATE. POSITION THE CLAMP BRACKETS IN THE HOLES AT THE TOP AND BOTTOM OF THE TEMPERATURE CONTROLLER CASE. TIGHTEN THE SCREWS AGAINST THE FRONT PLATE SO THAT THE TEMPERATURE CONTROLLER IS CLAMPED IN PLACE. REPLACE THE FRONT PLATE ON THE MOUNTING BOX. SELECT A WALL OR PANEL FOR THE MOUNTING BOX WHERE THE INSTRUMENT IS AWAY FROM THE HEAT AND WHERE IT CAN BE EASILY READ. WIRE UP THE TEMPERATURE CONTROLLER AS SHOWN ON THE WIRING DIAGRAM. ALLOW ENOUGH SLACK IN THE FLEXIBLE CONDUIT TO REACH THE MOUNTING LOCATION. BOLT THE MOUNTING BOX TO THE WALL OR PANEL.

JOHNSON GAS APPLIANCE

520 E Ave. NW * Cedar Rapids, IA 52405 Ph: 319-365-5267 or 1-800-553-5422

FORM A-1996

SUGGESTED METHODS OF VENTING JOHNSON #120 & #121 FURNACES

HEAVY GAUGE SHEET METAL SHOULD BE USED FOR HOOD & STACK.
 CLASS "A" VENT PIPE RECOMMENDED. NOTE: IF AN EXHAUST FAN
 IS USED AND THE EXHAUST TEMP. ENTERING THE VENT WILL BE
 LESS THAN 550° F., A CLASS "B" VENT CAN BE USED.

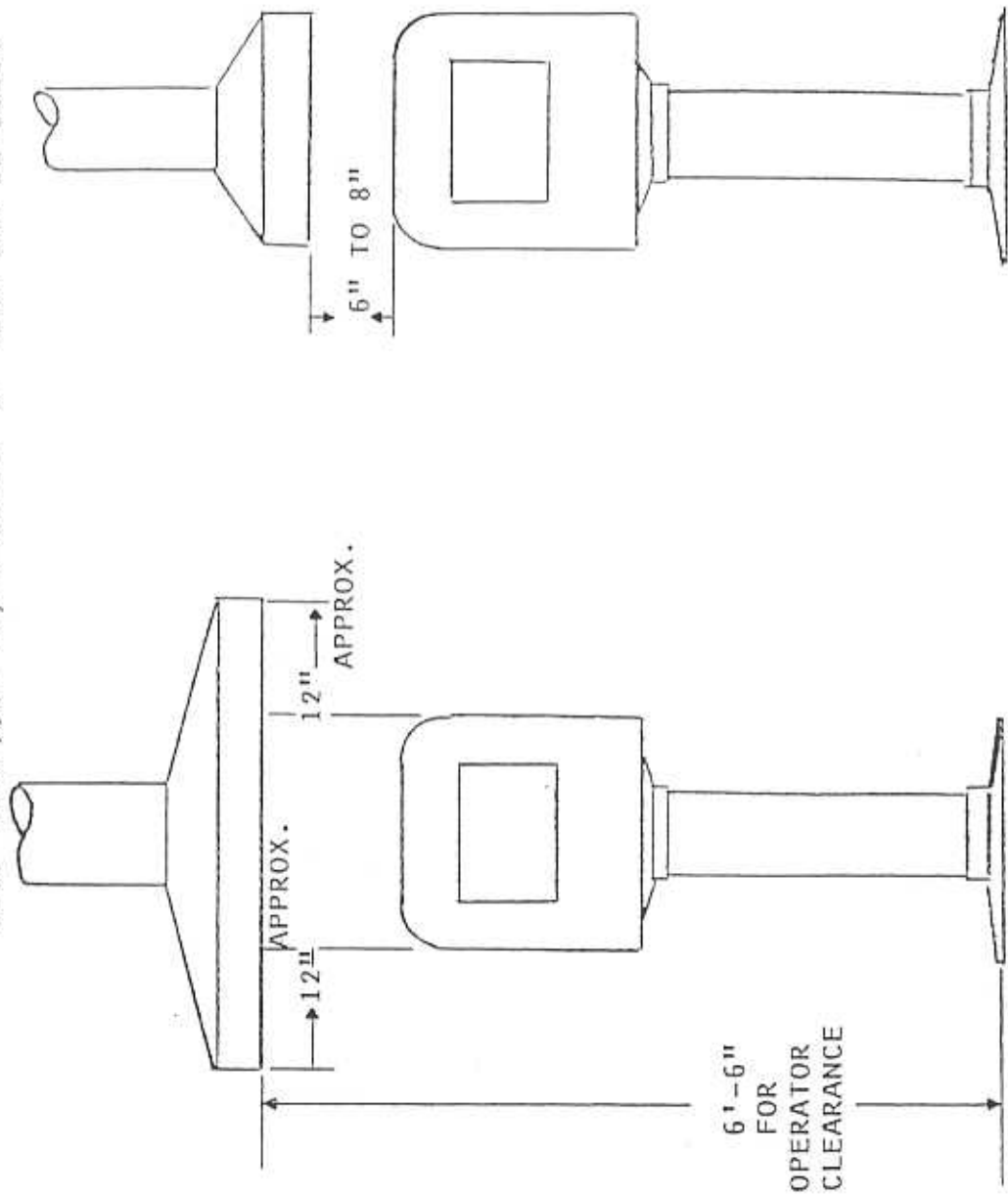

METHOD #1
 EXHAUST FAN REQUIREMENT:
 1500 C.F.M.

METHOD #2
 EXHAUST FAN REQUIREMENT:
 500 C.F.M.

VENTING REQUIREMENTS FOR
JOHNSON FURNACES

1. POT FURNACES, FORGES, AND MELTING FURNACES.

SINGLE UNITS OR MULTIPLE INSTALLATIONS

FOR EXHAUST HOODS APPROXIMATELY 6' 6" TO 7' ABOVE FLOOR, THE EXHAUST FAN SHOULD BE SUFFICIENT TO PROVIDE A 200 FPM FACE VELOCITY AT THE HOOD.

2. OVEN TYPE FURNACES (INCLUDES OVEN FORGES)

A. SINGLE INSTALLATIONS

FOR SINGLE INSTALLATION THE VENT REQUIREMENTS SHOULD REDUCE FLUE GAS TEMPERATURE TO 500 OR BELOW. FOR CFM REQUIREMENTS, DIVIDE BTU INPUT OF THE FURNACE BY 225. (APPLICABLE WHERE THE VENT HOOD IS 6" TO 8" ABOVE EXHAUST OPENING.)

B. FOR SINGLE OR MULTIPLE INSTALLATIONS WHEN SINGLE EXHAUST HOOD IS 6' 6" TO 7' ABOVE FLOOR, PROVIDE FOR A 200 FPM FACE VELOCITY.

FORM NO. A-2072

SEQUENCE OF EVENTS
WHEN USING THE UVM-1D ULTRA-VIOLET
SAFETY SYSTEM

- 1] PUSH START BUTTON.
- 2] MAIN STARTING RELAY IS ENERGIZED.
- 3] BLOWER MOTOR STARTS AND FLAME SAFEGUARD IS ENERGIZED.
- 4] BLOWER MOTOR COMES UP TO SPEED. AIR SWITCH ON BLOWER MOTOR CLOSES.
- 5] AT THIS POINT THE FLAME SAFEGUARD BEGINS ITS PROCESS.
- 6] AFTER AN APPROXIMATE 14 SECOND DELAY FOR "PRE-PURGE" AND IGNITION TEST, THE IGNITER PLUG FIRES. A SPLIT SECOND LATER THE GAS SOLENOID VALVE OPENS AND COMBUSTION TAKES PLACE.
- 7] THE ULTRA-VIOLET SAFETY SCANNER SENSES THE ULTRA-VIOLET IN THE FLAME. THE FLAME SAFEGUARD IS SATISFIED AND GOES INTO A "RUN" CIRCUIT.
- 8] THE UNIT WILL CONTINUE TO RUN UNTIL THE STOP BUTTON IS PUSHED.
- 9] A TEMPERATURE CONTROL DEVICE CAN ALSO BE INSTALLED WHICH WILL TURN THE UNIT OFF AND ON AUTOMATICALLY.

TROUBLE SHOOTING

THE FOLLOWING EVENTS CAN OCCUR THAT WILL EFFECT THE NORMAL OPERATION OF THE UVM-1D SAFETY SYSTEM:

1. THE START BUTTON IS PUSHED AND THE BLOWER MOTOR COMES ON, BUT THE UNIT FAILS TO IGNITE. THE FLAME SAFEGUARD WILL GO INTO A SAFETY SHUT-DOWN. A SAFETY SHUT-DOWN IS DESCRIBED AS FOLLOWS:

THE UNIT ATTEMPTS TO LIGHT, BUT THERE IS NO FLAME DETECTED WITHIN THE 4-10 SECOND IGNITION TEST. THE GAS SAFETY SOLENOID VALVE WILL CLOSE. THE FLAME SAFEGUARD STARTS A BI-METAL WARP SWITCH WHICH WILL TAKE FROM 30-90 SECONDS TO WARP OUT. AT THE END OF THIS TIME THE RED LOCKOUT LIGHT WILL COME ON. THE RED LIGHT INDICATES THAT ALL SYSTEMS ARE SHUT DOWN AND OPERATING CORRECTLY EXCEPT THE BLOWER MOTOR WHICH WILL CONTINUE TO OPERATE. AT THIS POINT THE STOP BUTTON SHOULD BE PUSHED. WAIT 3 MINUTES AND PUSH THE RED RESET BUTTON ON THE FLAME SAFEGUARD AND ATTEMPT TO RELIGHT THE UNIT.

2. THE START BUTTON IS PUSHED. THE BLOWER MOTOR COMES ON. THE UNIT LIGHTS AND IS OPERATING PROPERLY, BUT THERE IS A GAS INTERRUPTION. AT THIS TIME THE FLAME SCANNER SENSES THAT THERE IS NO ULTRA-VIOLET OR FLAME IN THE COMBUSTION CHAMBER. THE UNIT WILL ATTEMPT TO RELIGHT FOR A TEST PERIOD OF 4 SECONDS. IF REIGNITION DOES NOT OCCUR WITHIN THE 4 SECOND TIME PERIOD THE GAS SAFETY SOLENOID VALVE WILL CLOSE AND THE FLAME SAFEGUARD WILL GO INTO ITS SAFETY SHUT-DOWN PROCESS.
3. THE START BUTTON IS PUSHED, THE UNIT LIGHTS AND IS OPERATING PROPERLY, BUT THERE IS AN ELECTRICAL INTERRUPTION WHICH CAUSES THE MAIN LATCHING RELAY TO DROP OUT. AT THIS TIME THE UNIT WILL COMPLETELY SHUT DOWN INCLUDING THE BLOWER MOTOR AND IT WILL BE NECESSARY TO RESTART THE UNIT FROM THE BEGINNING. ANY TIME THERE IS AN ELECTRICAL INTERRUPTION THE LATCHING RELAY WILL DROP OUT. THIS IS A SAFETY FACTOR THAT WILL NOT ALLOW THE UNIT TO RESTART ON ITS OWN. FOR INSTANCE IF THE UNIT WAS NOT BEING ATTENDED THE UNIT SHOULD NOT BE ABLE TO COME BACK ON WITHOUT THE OPERATOR KNOWING WHAT HAD HAPPENED TO THE STANDARD PROCESS.

4. THE START BUTTON IS PUSHED. THE UNIT FIRES AND IS OPERATING PROPERLY. BUT, THE BRUSHES ON THE MOTOR ARE WORN OUT, OR THE FAN WHEEL COMES LOOSE FROM THE BLOWER MOTOR SHAFT. AT THIS TIME AIR PRESSURE WILL DROP IN THE BLOWER HOUSING COMPARTMENT AND CAUSE THE AIR SWITCH TO OPEN AND STOP THE ELECTRICITY FLOW TO THE GAS SOLENOID VALVE. THE GAS SOLENOID VALVE WILL CLOSE. AT THIS POINT THE FLAME SCANNER WILL NOT DETECT ANY ULTRA-VIOLET AND THE UNIT WILL GO INTO A SAFETY SHUT-DOWN PROCESS.
5. THE START BUTTON IS PUSHED AND THE UNIT ATTEMPTS TO LIGHT, BUT THERE IS NO SPARK. THE GAS VALVE WILL OPEN FOR A PERIOD OF 4 SECONDS AND ATTEMPT TO LIGHT. AT THIS TIME THERE IS NO ULTRA-VIOLET DETECTED BECAUSE THERE IS NO FLAME AND THE UNIT WILL GO INTO A SAFETY SHUT-DOWN PROCESS.
6. THE START BUTTON IS PUSHED, THE BLOWER MOTOR STARTS AND THE IGNITER COMES ON, BUT THERE IS NO IGNITION. THIS MAY BE DUE TO NOT HAVING ANY GAS SUPPLY; THE BLOWER MOTOR NOT RUNNING DUE TO NEEDING BRUSHES OR BEING BURNED OUT; THE COIL IN THE SOLENOID VALVE BEING BURNED OUT; THE AIR SWITCH NOT BEING CLOSED; THE IMPELLER WHEEL COMING LOOSE FROM THE BLOWER SHAFT, OR THE FLAME SAFEGUARD NOT GIVING A SIGNAL TO OPEN THE SOLENOID VALVE FOR IGNITION. AT THIS TIME THERE IS NO ULTRA-VIOLET DETECTED BECAUSE THERE IS NO FLAME AND THE UNIT WILL GO INTO A SAFETY SHUT-DOWN PROCESS.
7. THE START BUTTON IS PUSHED AND NOTHING HAPPENS AT ALL. A FUSE MAY HAVE BLOWN, A CIRCUIT BREAKER MAY HAVE TRIPPED, OR THE LATCHING RELAY MAY BE DEFECTIVE. THESE WILL NEED TO BE CHECKED OUT.
8. THE START BUTTON IS PUSHED. THE LATCHING RELAY CLICKS IN OR PULLS IN, BUT NOTHING ELSE HAPPENS. THE CHANCES ARE THE CONTACTS ARE DIRTY IN THE LATCHING RELAY. THE RELAY SHOULD BE REPLACED OR THE CONTACTS SHOULD BE CLEANED.
9. THE START BUTTON IS PUSHED. THE BLOWER STARTS AND NOTHING ELSE HAPPENS... A TIME PERIOD OF 2-3 MINUTES MAY GO BY AND THE BLOWER MOTOR CONTINUES TO RUN. CHANCES ARE YOU HAVE WHAT IS DESCRIBED AS A "RUN-A-WAY" SCANNER. A RUN-A-WAY SCANNER IS:

THE START BUTTON IS PUSHED AND THE BLOWER MOTOR COMES ON AND NOTHING ELSE HAPPENS. YOU MAY WAIT FOR 2, 3 OR 5 MINUTES AND STILL NOTHING HAPPENS. WITH THE UNIT STILL RUNNING, UNSCREW THE FLAME SCANNER FROM THE SIDE OF THE FURNACE AND CUP IT IN YOUR HANDS OBSERVING THE GLASS EYE END THAT WOULD NORMALLY "SEE" THE FLAME. IF THERE IS A "FLICKER" IN THE SCANNER IT MEANS THAT THE SCANNER IS DEFECTIVE. IT ALSO MEANS THAT IT IS SENDING A PREMATURE SIGNAL TO THE FLAME SAFEGUARD AND IT IS SATISFIED THAT THE UNIT IS BURNING AND IT DOES NOT NEED TO IGNITE OR OPEN ANY GAS VALVE. THIS IS A GOOD FEATURE BECAUSE IT TELLS YOU WHEN THE FLAME SCANNER NEEDS TO BE REPLACED. IT WILL ALSO NOT ALLOW THE COMBUSTION PROCESS TO TAKE PLACE AND POSSIBLY CREATE AN UNSAFE OPERATING CONDITION. THE FLAME SCANNER MUST BE REPLACED.

ANY FURTHER QUESTIONS REGARDING THE OPERATION OF THE ULTRA-VIOLET SAFETY SYSTEM SHOULD BE DIRECTED TO TECHNICAL SALES.

Johnson Gas Appliance Company
520 E. Avenue N.W.
Cedar Rapids, IA 52405.

[319] 365-5267 or 1-800-553-5422

FAX 319-365-6282

MAINTENANCE INSTRUCTIONS FOR JOHNSON FURNACES

Johnson equipment is designed to give the longest possible service at the lowest maintenance cost. Due to the high temperatures reached by Johnson furnaces certain repairs are required from time to time to keep them in good operating condition. We are listing below pertinent maintenance information.

OVEN TYPE HEAT TREATING FURNACES [#70, #120, #121, #142, #143, #654, #706]

A. GENERAL MAINTENANCE:

These furnaces are lined with high temperature insulating refractory. This refractory expands and contracts as the furnace heats and cools; and cracks will appear throughout the lining. These are normal and should not be cause for alarm and should NOT be filled with cement as it will cause the brick to spall. The door brick on the #70, #120, #121 & #654 furnaces should be replaced occasionally. It is furnished with inconel screws and washers to withstand the high temperatures. The door should NOT be used as a shelf or parts dragged across the door brick in the process of removing parts from the furnace. Also, avoid striking the sides of the furnace with tongs. The hearth plate will require replacement occasionally, as will the front and back hearth rests on which the plate is set. The hearth plate must be used with the channel edges up. Parts to be heated should be pre-heated or brought up to temperature with the furnace when possible; avoid placing a cold piece on a hot hearth plate. When the gas is turned off to the furnace, turn off the blower at once so the lining will cool gradually.

B. FURNACE RELINING AND FURNACE EXCHANGE:

The furnace should be used until the complete lining is considerably deteriorated. It should then either be replaced with a new lining or new furnace body from the factory. Complete sets of fire brick linings with special shapes to fit the furnace and cement for sealing the brick are available with easy-to-follow installation instructions. Many operators, however, prefer to take advantage of the special price on replacement furnace bodies. Check our repair parts list for prices. This method is popular because it insures an expertly relined furnace in operation at all times; it eliminates the time and trouble of relining the furnace in the customer's shop; and it eliminates the "down" time for returning to the factory for relining. WHEN ORDERING, SPECIFY IF FURNACE IS TO HAVE SAFETY PILOT PORT INSTALLED. FOR ADDITIONAL INFORMATION ON SAFETY EQUIPMENT SEE PAGE 3.

PYROMETER EQUIPMENT:

Occasional replacement must be made of the thermocouple elements, the protection tubes or of the complete thermocouple assembly. We carry replacement parts in stock for immediate delivery.

POT TYPE FURNACES [#920, #950, #568, #580, #565, #565A, #521, #575, #575A, & #575B]

A. FURNACE RELINING:

These furnaces are lined with a high-quality, wear-resistant, castable lining poured with molds used in our factory. These linings are very rugged, and the furnaces should be used until the linings are considerably deteriorated, and then replaced with new furnace bodies. The new bodies are furnished complete less blower equipment and pots or crucibles. Prices for the new bodies are given on the repair parts list. With this method the customers are assured of an expertly lined furnace; and they are never without a furnace to use in their shops. If the lid lining needs replacement before the furnace body, material can be supplied to be mixed with water and molded into the furnace lid or a refractory lid can be supplied.

B. FURNACE RELINING #900 CRUCIBLE FURNACE:

This furnace is lined with a precast lining that can be replaced in the shop or a new replacement body can be supplied.

C. USE OF POTS:

DO NOT use a pressed steel pot for melting aluminum. A graphite crucible is used in the crucible furnaces. A cast iron pot is also suitable when contamination of aluminum by the cast iron is not objectionable.

To extend pot life carry a neutral or slightly reducing flame [more gas than air]. A flame that is too blue is oxidizing and will cause rapid scaling of the pot.

Avoid infiltration of cyanide or other salts into the combustion chamber. If seepage or splashing is occurring, place a ring of dry, powdered fire clay under the flange of the pot.

Turn the pot a little each day so that a different part is exposed to the hottest gases.

Remove sludge or sediment from pot at least once a day. This acts as an insulator, causing local overheating of pot.

Remove the pot at regular intervals and thoroughly clean the inner surface. Also hammer off thin scale that forms on outside.

D. USE OF CRUCIBLES:

Crucibles should be kept in a warm, dry area. Before using a new crucible anneal it by placing it in a warm furnace and gradually raising the temperature at about five minute intervals over a period of forty five minutes until the crucible becomes red.

BLOWER MOTORS:

Motors on the blowers should be oiled occasionally. The brushes should be checked and replaced periodically to avoid wear on the armature.

FORGE FURNACES [#122 & #133]

The forge furnaces are lined with hard firebrick on all wearing surfaces. Individual firebricks can be easily replaced when desired. Lining for the lid or complete lining can be replaced when necessary. Sets of linings are furnished with simple instructions for installation.

SOFT METAL MELTING FURNACES [#379, #313 & #616]

A. FURNACE RELINING:

These furnaces can be relined with brick and castable material supplied by our Company. An instruction sheet accompanies the shipment.

B. GENERAL MAINTENANCE:

Avoid permitting metal to solidify in the pots. If the metal does "freeze" in the pot, turn one burner only on until the metal melts slowly; do not turn all burners on at once or the pot will crack. When melting metal, let small amount of metal form a molten pool before adding additional metal.

SMALL BENCH FURNACES [#101, #112, #108 & #118]

The burner tubes on these furnaces are slotted on the ends to retain the flame, and care should be taken about striking the ends with soldering irons. These tubes are made of cast iron and will give long service, but when the slots are knocked off, the tubes should be replaced to insure good combustion. The #108 and #118 furnaces are equipped with individual valves for each burner. The #101 and #112 furnaces are equipped with double valves. After considerable use the valve plugs will tighten causing the valves to "freeze". When this happens the complete valve will should be replaced as prompt replacement of the complete valve will avoid gas leakage. Linings for all these furnaces are carried in stock. Lining sets are supplied for those in which both hood and bottom are lined. This set consists of material to be molded in to the furnace body and includes a new angle iron.



APPROVED COMPONENTS FOR INDUSTRIAL FURNACES

Approved components used on our industrial furnaces and power burners with flame rod or thermocouple safety and ultra-violet safety.

JOHNSON PARTS	APPROVAL		
	UL	CSA	OTHER
Baso Switch	√		
Baso Valve		√	AGA
Baso Thermocouple			AGA
Baso Pilot w/Orifice		√	AGA
Air Switch	√		
ITT Solenoid Valve	√		Factory Mutual
Transformer	√	√	
Lock Out Light	√		
Ignition Button	√	√	
1/30 Motor Bodine	√	√	
1/7 Carter Motor	√		
1/3 Motor w/ back Contact	√		
P & B Relay	√	√	
Speed Control Switch	√	√	
Start - Stop Switch			Top/Application Only
Ignition Wire	√		
All Other Wire	√		
3/4 Gas Pressure Regulator			AGA
OJ21 Ignitor Plug	√		
Gas Adjustment Valve	√		
Fireye Control	√		
Flame Rod 12"	√		
Scanner	√		

NOTE: All Johnson Gas Industrial Furnaces are factory tested for proper function of all systems and all piping is leak tested.

JOHNSON GAS APPLIANCE COMPANY • 520 E AVENUE N.W. • CEDAR RAPIDS, IOWA 52405

1-800-553-5422 • 319-365-5267 • FAX 319-365-6282



Johnson

WARRANTY

We warrant our equipment to be free of workmanship or material defects. Should any material prove defective within one year after shipment due to faulty material or improper workmanship we will furnish without charge to the original purchaser, replacement or repair of said defective part or parts returned freight prepaid to Johnson Gas Appliance Company, Cedar Rapids, Iowa. The foregoing shall not apply to equipment that has been altered or repaired after shipment to you by anyone except our authorized employees, and the Company will not be liable in any event for alterations or repairs except those made with its written consent. On material not of our manufacture, the manufacturer's guarantee to us is extended. This paragraph does not cover ordinary wear and tear, corrosion or improper handling or storage after leaving our point of shipment. If inspection by the Company does not disclose any defect in workmanship or material, the Company's regular charges will apply. Any refractories supplied with this order will be warranted as to quality and will be selected in accordance with good practice for the service intended. The foregoing obligations are in lieu of all other obligations and liabilities including negligence and all warranties, or merchantability or otherwise, express or implied in fact or by law, and state our entire and exclusive liability and buyer's exclusive remedy for any claim or damages in connection with the sale or furnishing of goods or parts, their design, suitability for use, installation or operation. We will in no event be liable for any special or consequential damages whatsoever, and our liability under no circumstances will exceed the contract price for the goods for which liability is claimed.

JOHNSON GAS APPLIANCE COMPANY • 520 E AVENUE N.W. • CEDAR RAPIDS, IOWA 52405

1-800-553-5422 • 319-365-5267 • FAX 319-365-6282

Manufacturers since 1901 / Heat Treating Furnaces / Industrial Gas Burners / Stock Tank Heaters / Concrete Curing Systems